

---

*565 Series Manual*  
*BAF, BIF, BIFMN Chem-Free Filter*

---

***NEW STYLE PARRALEL TANK ADAPTOR***

**Read all instructions carefully before operation.**

Rev 0, May 16, 2017

54594-1

---

# **TABLE OF CONTENTS**

System Specifications .....	3
How the System Works .....	3
Main Valve functions.....	5
Manual Regeneration.....	5
Sizing Requirements.....	5
Before Installation.....	7
General Installation.....	8
Start Up Instructions .....	9
Plumbing System Clean-Up .....	10
Level I Programming .....	11
Level II Programming .....	12
System Configuration.....	13
Maintenance .....	14
Valve Drive Assembly Exploded View .....	15
Control Valve Assembly Exploded View .....	16
Trouble Shooting.....	18
Warranty .....	19

## System Specifications

Specifications	565 BAF-100	565 BAF-150	565BIF-100	565BIF-150	565BIFMN-100	565BIFMN-150
Typical Service Flow Rate	3.0gpm	4.0gpm	3.0gpm	4.0gpm	3.0gpm	4.0gpm
Peak Flow Rate	5.0gpm	8.0gpm	6.0gpm	10.0gpm	6.0gpm	10.0gpm
Backwash Flow Rate	5.0gpm	5.0gpm	5.0gpm	5.0gpm	5.0gpm	5.0gpm
Filter Media Volume - Cubic Feet	1.0ft <sup>3</sup>	1.5ft <sup>3</sup>	1.0ft <sup>3</sup>	1.5ft <sup>3</sup>	1.0ft <sup>3</sup>	1.5ft <sup>3</sup>
Filter Tank Size	10x44	10x54	10x44	10x54	10x44	10x54
Air Contact Tank Size	8x44	10x54	8x44	10x54	8x44	10x54
Shipping Weight	150lbs	188lbs	150lbs	188lbs	150lbs	188lbs
Media Loaded	Yes	Yes	Yes	Yes	Yes	Yes
Maximum Iron	30.0ppm		30.0ppm		30.0ppm	
Hydrogen Sulfide	5.0ppm		5.0ppm		5.0ppm	
Manganese	0.0ppm		0.0ppm		1.0ppm	
Iron Bacteria Removal	No		Yes		Yes	
pH	7.0- 8.5		7.0- 8.5		6.0- 6.9	
Plumbing Connections	3/4" (Optional 1")					
Electrical Requirements	Input 120V 60 Hz - Output 12V 680mA					
Water Temperature	Min 39 - Max 100degrees Fahrenheit					
Water Pressure	Min 20- Max 125psi					

Figure 1. System Specifications

**Caution:** These water filters are not intended to be used for treating water that is microbiologically unsafe or of unknown quality without adequate disinfection before or after the system.

- Peak flow rates are intended for intermittent use only and are for residential application only
- At the stated service flow rates, the pressure drop through these devices will not exceed 15 psig
- The manufacturer reserves the right to make product improvements which may deviate from the specifications and descriptions stated herein, without obligation to change previously manufactured products or to note the change

## How The System Works

The chemical free iron filter consists of three major components which are: Control Valve, Air Tank, Media Tank

Incoming raw water passes through a pocket of air in the first tank. The oxygen in the air oxidizes the iron into a solid form and it removed when it passes through the second filter tank. The media in the second filter tank acts as a catalyst in the reaction between the iron and oxygen that causes the iron to precipitate into a solid so it can be filtered out of the water.

As more water passes through the unit, the air becomes depleted in the first tank and the filter media in the second tank becomes over loaded with iron. A periodic automatic regeneration replenishes a supply of air and cleans the iron out of the filter tank.

There are no chemicals used for this system to work. On "BIF" or "BIFMN" models the filter media automatically adjusts the pH to neutral or higher on acid water without an acid neutralizer. The ability to raise pH when it is below neutral (7 or less) greatly enhances the filter's ability to remove iron efficiently. The clean, filtered water then flows into your household water line. Depending on water use and the concentration of iron in your water, periodic backwashing is required to flush the entrapped iron from the system. The system can be set to regenerate as clock every 1 – 99 days or as meter delayed based on gallons between regenerations.

Instructions for calculating the backwash frequency and setting the controls are in Section 5.

Your filter is factory set to backwash at 12:00 a.m. during a period of little or no water use. The automatic regeneration cycle lasts approximately 60 minutes, after which filtered water service is restored. While backwashing is taking place raw water

automatically bypasses the filter if required. If possible, avoid using water during backwashing to prevent iron-laden water entering your household plumbing system.

This valve is controlled with simple, user-friendly electronics displayed on a large LCD screen. The main page displays the current date and time. In addition, the main page also shows key valve information and statistics including; current capacity setting, volume remaining, date of last regeneration, current flow rate, and peak flow rate.

MAY 8, 2009 9:05 AM	CAPACITY 1,350 GAL	VOLUME REMAINING 1,125 GAL
REGEN DAYS 7 DAYS	REMAINING DAYS 5 DAYS	REGENERATION TIME 2:00 AM
LAST REGEN MAY 4, 2009	CURRENT FLOW 1.5 GPM	PEAK FLOW 5.8 GPM

Figure 2. Main Page Displays

**NOTE:** REGEN DAYS and REMAINING DAYS are only shown in the CALENDAR CLOCK mode or METER OVERRIDE mode.

Your automatic filter can be set to operate according to your needs by programming the appropriate settings. On the days your filter regenerates, the operating cycles will be automatically performed. In the service position, filtered water is supplied for household use.

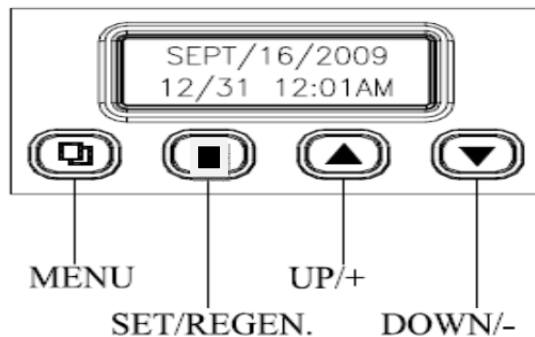

Figure 3. Valve Button Configuration

**MENU BUTTON “□”:**  
settings can

The function of this key is to enter the level one programming mode where the valve be adjusted.

**SET / REGEN BUTTON “□”:**  
button

This button has two functions. The first is to initiate a manual regeneration by holding the for 3 or more seconds. The second function is while in programming mode, pressing this key allows the user to change the value of each setting.

**UP / DOWN “▲▼”:**

These buttons are used to increase or decrease the value of the settings while in the programming mode.

### **System Initialization**

When power is first supplied, the valve may take up to two minutes to initialize the valve. During this time the valve will show “INITIALIZING WAIT PLEASE”. Do not touch any buttons at this time. When the valve reaches the service position, it will display the current date and time.

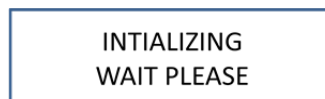

Figure 4. Initializing Display

## Main Valve Functions

---

**Regeneration Mode** There are four ways of initiating a regeneration.

1. METER DELAYED
2. METER IMMEDIATE
3. CALENDAR CLOCK (Factory Setting)
4. METER OVERRIDE

**Capacity Calculation** The control can automatically calculate the capacity of the system using the parameters entered in Level I programming. If you prefer to enter the capacity manually, choose the MANUAL option.

1. AUTOMATIC
2. MANUAL (Factory Setting)

**Adjustable Cycles** All of the valve cycles are fully adjustable.

1. BACKWASH
2. BRINE (Air Draw) **\*\* note there is no rinse or refill for this model \*\***

**NOTE:** Refer to Level Two User Programming for description of each mode.

During a regeneration cycle, the valve will display what position it is advancing to. Once in the correct position, the valve will display the current position along with the time remaining for that cycle. On the bottom row, the time remaining is also graphically displayed.



Figure 5. Regeneration Display

If you run out of filtered water because of inadequate regeneration frequency, inadequate reserve capacity, power failure or unusually high water usage, you can initiate a manual regeneration. The filter will now automatically complete a regeneration cycle and return to service. If possible, avoid water use during the regeneration cycle.

Once you have set your filter you may experience frequent loss of water pressure, you may have to increase the frequency of regeneration by decreasing the number of days between regeneration.

## Manual Regeneration (Delayed or Immediate)

---

If screen is locked, press “ MENU” for 3 seconds to unlock. To initiate an immediate regeneration, press the SET / REGEN button for 3 seconds, an option for delayed or immediate regeneration will appear. Press the SET / REGEN button again and delayed will begin flashing, press the down arrow button to have immediate flash, press the SET / REGEN button and then press the menu button and the valve will immediately start into manual regeneration.

To initiate a delayed regeneration, press the SET / REGEN button for 3 seconds, then press the menu button and a regeneration will be queued to the next pre-set regeneration time (2:00 a.m.).

## Sizing Requirements

---

### Water Pressure

The water system must have a pump big enough to deliver the recommended backwash rate with a minimum pressure at the inlet of the filter of 30 psi. If the existing system cannot do this, it must be upgraded to do so. Your chemical free iron filter system is designed to operate under normal water pressures from 30 psi to 50 psi.

**NOTE:** This system is compatible with constant pressure or variable speed pumps.

## **CHECK YOUR WATER PRESSURE AND PUMPING RATE**

Two water system conditions must be checked carefully to avoid unsatisfactory operation or equipment damage:

1. Minimum water pressure required at the filter tank inlet is 30 psi.
2. The pumping rate of your well pump must be at least **5 gallons per minute (gpm)** for satisfactory back wash of the filter. To measure the pumping rate of your pump, follow these instructions:
  - a. Make certain no water is being drawn. Open spigot nearest pressure tank. When pump starts, close spigot and measure time (in seconds) to refill pressure tank (when pump shuts off). This figure represents cycle time.
  - b. With the pressure tank full, draw water into a container of known volume, and measure the number of gallons drawn until the pump starts again. This is draw-down. Divide this figure by cycle time and multiply the result by 60 to arrive at the pumping rate in gallons per minute (gpm). To aid in your calculation, insert the date in the following formula:

DRAW-DOWN \_\_\_\_\_ ÷ CYCLE TIME \_\_\_\_\_ x 60 = PUMPING RATE \_\_\_\_\_ (gpm)

**EXAMPLE:** CYCLE TIME is 53 secs.; DRAW-DOWN is 6 gals.; then, PUMPING RATE equals:  
6 gals. ÷ 53 secs. x 60 = 6.8 gpm

**NOTE: If your pumping rate is inadequate, do not install your filter until problem is corrected.**

### **Backwash Flow Rates**

The most important criteria in sizing a filter is the capacity of the pump. The water must pass through the filter media at a service flow rate that allows it to operate properly. The filter must also be backwashed at a flow rate sufficient to dislodge and remove captured particulates. Failure to provide sufficient water will cause a build-up of particulates in the filter media, impairing its filtration ability. In order for your filter to backwash and rinse properly, your pump must be capable of providing the backwash flow rates indicated in the above specification chart.

### **Backwash Frequency**

This unit is factory set for backwash every 600 gallons with a 4 day over ride. More frequent backwash may be required based on water conditions and amount of water used.

Refer to Level II Master Programming to change the REGEN days (backwash frequency).

## **Before Installation**

---

### **INSPECTION AND HANDLING**

Inspect the equipment for any visible shipping damage. If damaged, notify the transportation company and request a damage inspection. Damage to cartons should also be noted. Handle the filter unit with care. Damage can result if dropped or if set on sharp, uneven projections on the floor. Do not turn the filter unit upside down. NOTE: If a severe loss in water pressure is observed when the filter unit is initially placed in service, the filter tank may have been laid on its side during transit. If this occurs, manually backwash the filter to "reclassify" the media.

### **IRON (Fe)**

Iron concentrations as low as 0.3 ppm will cause staining. The iron concentration, together with the flow rate demand and the consumption rate of the water determines the basic size filter system. The higher these factors are, the larger the required system. The filter system is capable of filtering out the three main types of iron found in water supplies: Soluble iron (also known as "clear water" or ferrous iron), precipitated iron (also known as "red water" or ferric iron) and bacterial iron (BIF or BIFMN models only). There is no apparent upper limit of iron concentration for the filter, but special care must be taken when selecting a filter model if your water has a combination of high iron, very low pH and/or manganese.

### **MANGANESE(Mn)**

The presence of manganese can be bothersome, even for a chemical free iron filter. As little as 0.05 mg/l of manganese can produce a brownish or black stain. The ability of the BAF model filter to remove manganese is very limited. If manganese is present it is recommended you choose a BIFMN filter unit.

### **pH**

The pH of water measures its acidity or its alkalinity. Water with a pH of less than 7.0 is acidic, above 7.0 it is alkaline, and a pH of 7.0 is neutral. The lower the pH value is below 7.0 the greater the acidity, and the higher the pH value is above 7.0 the more alkaline. Acidic water (pH less than 7.0) is corrosive to pipes, appliances, etc. A pH of 7.0 or higher facilitates iron removal.

### **TANNINS (Humic Acid)**

Tannins (also known as humic acid) which are present in some water supplies, are the result of decaying vegetable matter. If the tannin concentration is above approximately 0.5 ppm, it will form a sticky coating on the media, thus rendering it incapable of filtering the iron. A chemical free iron filter is not recommended under this condition. If the tannin concentration is less than 0.5 ppm, a chemical free iron filter may be installed.

### **HYDROGEN SULFIDE (H<sub>2</sub>S)**

Hydrogen sulphide (often referred to as "sulphur"), is easily detectable by its objectionable "rotten egg" odour. Sulphur corrodes iron, brass, copper and silver. A chemical free iron filter is not recommended when hydrogen sulphide is the only water problem although it is capable of removing sulphur in concentrations of up to 5 ppm. Whenever hydrogen sulphide is present, backwashing must be performed at more frequent intervals.

**\*\* note \*\* a special media bed is available upon request for the treatment of Hydrogen Sulfide levels over 5ppm.**

### **LOCATE WATER CONDITIONING EQUIPMENT CORRECTLY: (see drawings page 9)**

1. Select the location of your filter tank with care. Various conditions **which** contribute to proper location are as follows:
  1. Locate as close as possible to water supply source.
  2. Locate as close as possible to a floor or laundry tub drain.
  3. Locate in correct relationship to other water conditioning equipment.
  4. Filters and softeners should be located in the supply line before the water heater. Temperatures above 120°F damage filters and softeners, and will void the factory warranty.
  5. Do not install a filter or softener in a location where freezing temperatures occur. Freezing may cause permanent damage to this type of equipment, and will void the factory warranty.
  6. Allow sufficient space around the unit for easy servicing.

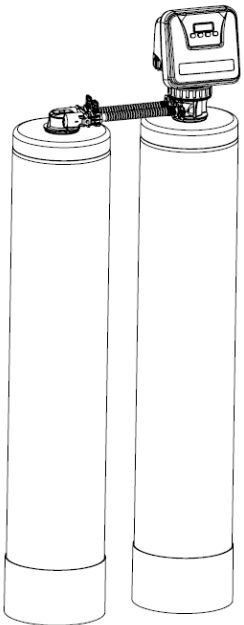

# General Installation

Water Pressure	Minimum 25 PSI
Electrical Supply	Uninterrupted AC 115V
Existing Plumbing	Free of any deposits or build-ups inside pipes.
Unit Location	Locate close to drain and connect according to plumbing codes
Bypass Valves	Always provide for bypass valve if unit is not equipped with one.
Plumbing	Softener and or other water treatment equipment should be installed to local plumbing codes

	<p><b>CAUTION</b></p> <ul style="list-style-type: none"> <li>▪ Do not exceed 120 psi water pressure.</li> <li>▪ Do not exceed 110°F water temperature.</li> <li>▪ Do not subject unit to freezing conditions.</li> </ul>
---	--

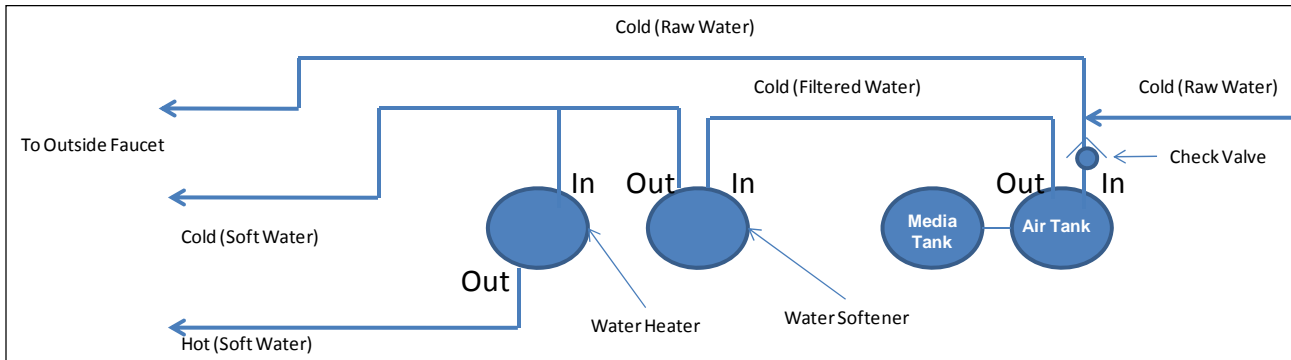

Figure 6. Tank Configuration

Figure 7. Typical Installation

1. Locate the Air and Media Tank close to a drain where the system will be installed. The surface should be clean and level.
2. Shut off all water at main supply. On a private well system, turn off power to pump and drain pressure tank. Make certain pressure is relieved from complete system by opening nearest faucet to drain the system. Shut off fuel supply to water heater.
3. Cut the main supply line as required to fit plumbing to the control valve with bypass.
4. Solder or solvent weld plumbing. Do not apply heat to any fitting connected to the control valve as damage may result to the internal parts. Check to be certain water supply pipe is connected to the control valve inlet fitting and pipe connected to control valve outlet fitting is in direction of house service.
5. Perform all plumbing according to local plumbing codes.
  - a. Use a ½" minimum pipe or tubing size for the drain line.
  - b. Use a ¾" pipe or tubing for backwash flow rates that exceed 7 gpm or length that exceeds 20ft (6 m)

**NOTE: ON COPPER PLUMBING SYSTEMS BE SURE TO INSTALL A GROUNDING WIRE BETWEEN THE INLET AND OUTLET PIPING TO MAINTAIN GROUNDING.**
6. Any solder joints near the valve must be done before connecting any piping to the valve. Always leave at least 6" (152 mm) between the valve and joints when soldering pipes that are connected to the valve. Failure to do this could cause damage to the valve.
7. Install ¾" check valve on inlet of bypass valve.
8. Connect the drain line to the valve. Only use Teflon tape on the drain fitting.
9. Place unit in the bypass position.
10. Slowly turn on the main water supply.
11. At the nearest cold treated water tap nearby remove the faucet screen, open the faucet and let water run a few minutes or until the system is free of any air or foreign material resulting from the plumbing work. Close the water tap when water runs clean.

## Start-Up Instructions

---

1. Ensure inlet and outlet of bypass are in closed positions.
2. Plug the valve into an approved power source. When power is supplied to the control, the screen may display "INITIALIZING WAIT PLEASE" while it finds the service position.
3. Press SET/REGEN "□" button and hold for 3 seconds to initiate a manual regeneration and advance the valve to the Backwash position.
4. Un-plug power cord and open the inlet on the bypass valve slowly and allow water to enter the unit. Allow all air to escape from the unit before turning the water on fully then allow water to run to drain for 25 to 30 minutes. For BIF or BIFMN models this is critical to prevent cementing of the bed.
5. Plug power cord back into power source. When power is supplied to the control, the screen may display "INITIALIZING WAIT PLEASE" while it finds the service position. Press SET / REGEN"□" button and hold for 3 seconds to initiate a manual regeneration and advance the valve to the Backwash position.
6. Press any button to advance to the BRINE (AIR DRAW) position. Check the drain line flow. Allow the water to run for entire BRINE (AIR DRAW) cycle.
7. Valve will automatically advance to the SERVICE position. Open the outlet valve of the bypass, then open the nearest treated water faucet and allow the water to run until clear, close the tap and replace the faucet screen.

## Plumbing System Clean-Up

---

The following procedures are guidelines only but have proven successful in most instances. Under no circumstances should any procedure outlined below be followed if contrary to the appliance manufacturer's instructions. Should there be any questions concerning the advisability of performing a procedure, it is strongly recommended the manufacturer's authorized service outlet be consulted prior to performing the procedure.

The plumbing system and water using appliances that have been exposed, even for a short time, to iron-fouled water need to be cleaned of the precipitated iron that has collected in them or iron bleed (staining) will continue to be a problem.

Depending on the amount of iron in the water and the length of time the water system has been exposed to iron fouling, select from the following procedures those that apply to the type of system and appliances that need to be cleaned to assure iron-free water at all points of use.

### Softener

It isn't uncommon that the softener was installed in an effort to remove ferrous (clear water) iron from the water supply. Typically a softener will remove some ferrous iron until the resin bed becomes fouled to the extent that it will lose both hardness removal capacity and the limited capacity for iron removal. This is the condition to expect the softener to be in when planning a system clean-up. Prior to closing the main supply valve or turning power off to a private well system and preparatory to installing the filter system, do the following:

1. Disconnect the brine draw line from the brine cabinet and place the loose end into a five gallon plastic pail filled with a solution of warm water and 4 oz. of resin mineral cleaner.
2. Advance the control timer to the brine draw position (refer to instructions provided with your softener). Allow all the warm mineral cleaner solution to be drawn into the mineral bed.
3. Then immediately close the main water supply valve or turn the power off to the pump and proceed with the filter installation. During the time required to install the filter system, the iron-fouled softener resin will be chemically cleaned.

4. After the filter installation is completed and final adjustments have been made, with the water turned on and the brine draw tube reconnected, reposition the timer on the softener to the backwash position. Allow the timer to perform an automatic regeneration cycle. During backwash of the softener, all iron cleaned from the resin will be washed down the drain. It is advisable, after chemically cleaning the softener, to regenerate the system twice to fully restore capacity lost due to iron-fouling.

### **Water Heater**

If the water heater has been exposed to both iron and hardness for a long period of time, replacement of the heater tank may be the only practical solution to prevent continued staining originating from this source. After completing the installation of the chemical free iron filter, clean the water heater by following these instructions:

1. Shut off the energy supply to the water heater and close the heater inlet water valve.
2. Drain hot water tank completely. Open inlet water valve, allowing heater tank to be refilled with iron-free water. Continue flushing until the water runs clear to the drain.
3. If, after approximately 30 minutes of flushing, water does not clear, terminate the flushing operation. Refill hot water heater with water and pour approximately 1/2 gallon of household bleach into the top of the heater tank. Allow bleach solution to stand in tank for 20 to 30 minutes. Flush the tank again until water is clear at the drain. Turn energy supply on.

**NOTE:** If water does not clear in approximately 10 minutes, water heater should probably be replaced.

### **Media Installation (When Necessary)**

1. Remove the tank adaptor from the second mineral tank.
2. Temporarily plug the open end of the central pipe in the tank to insure that no resin or gravel falls down into the distribution.
3. Fill mineral tank one quarter full of water to protect distribution during gravel installation.
4. Slowly and carefully add the gravel support bed and the softener or filtration media leveling each layer as it is placed into the tank.
5. Unplug the riser tube, carefully position the tank adaptor over it and turn it into the threads in the fiberglass tank, tightening securely into tank. Note: Ensure that the internal O-ring in the tank adaptor fits securely over the riser tube. Silicone grease or other food grade lubricant may be applied to the O-ring to ease installation of the riser tube. DO NOT use petroleum based lubricants as they will cause swelling of O-ring seals.

## BIF/BAF Regeneration Process Explained

**Backwash:** (minimum 30 psi inlet pressure required): During the backwash cycle, water enters tank #2 through the center of the distribution tube and flow upwards in the tank #2 expanding the media bed and carrying any precipitated contaminants trapped within the bed. It then travels to Tank #1 through the center of the distribution tube and flow upwards in tank #1 and then down to drain. At this point all of the air is evacuated from tanks #1 and #2.

**Air Draw:** The control valve draws the air from the atmosphere to Tank#1. There is a delay at the start of the cycle while the pressure of the air within the tank reaches the atmospheric pressure. During this time no air is drawn into the tank. Once the pressure has equalized air being drawn in to the unit will displace water in Tank #1 causing an air bubble to form at the top of Tank #1. At this time a small stream of water will run to the drain. While the unit is returning to the service position, a small amount of air will be released to the drain. THIS IS NORMAL.

**Static Service:** The unit returns to the Service position. The water compresses the air to the top of the tank#1. The actual size of the bubble in Tank #1 will vary depending on the on-site water pressure.

**Flowing Service:** During water consumption, the water will enter tank #1 causing the air bubble to expand allowing the oxidation process to begin. The water then enters Tank #2 and flow through the media for treatment. When the water flow stops the air bubble in Tank #1 will again compress.

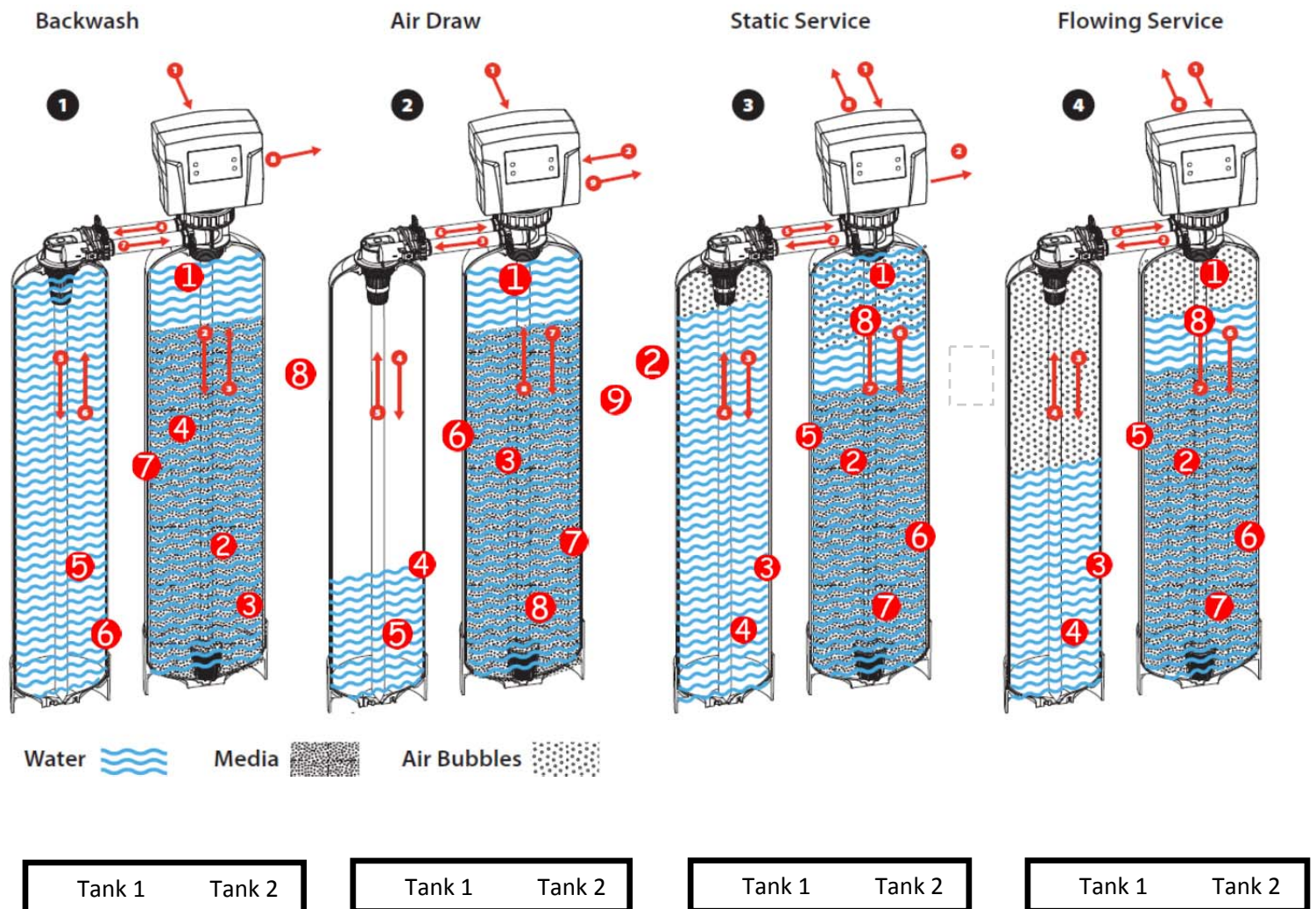

# Level I User Programming

## Setting Current Time

1. Press “**□**” for 3 seconds to unlock screen. Press “**□**” again to enter level one programming mode and adjust CURRENT TIME.
2. Press “**□**” to adjust hours. When you have entered the change value mode, the cursor will blink. Press “**▲** or **▼**” arrows to change the hour values. Press “**□**” again to accept the hour value and advance to change the minutes value. Press “**▲** or **▼**” arrows to change the minute values. Press “**□**” again to accept the minute values and advance to adjust the AM/PM values. Press “**▲** or **▼**” to change the AM/PM value. Press “**□**” again to accept the AM/PM value and exit. When you have exited the change value mode, the cursor will stop flashing.

## Setting Current Date

1. Press “**▼**” to advance to CURRENT DATE.
2. Using the same procedure as setting the time, press “**□**” to enter value change mode.

## Setting Vacation Mode

1. Press “**▼**” to advance to VACATION MODE.
2. Press the “**□**” to change the value. Press “**▲** or **▼**” to change the values.

## Exiting Level One User Program Mode

1. At any time, press the “**□**” to accept all changes and return to main page display.

Level I User Program Mode (Filter)		
PARAMETER	OPTIONS	DESCRIPTION
1	CURRENT TIME	This option is the current time of day.
2	CURRENT DATE	This option is the current date. The date is used to track the last time the system regenerated.
5	Yes	This function may be activated by the user during a prolonged absence such as vacation. The system will perform a brief backwash and rinse based on the advanced setting. The purpose is to keep the water fresh in the softener tank and plumbing system.
	No	

Figure 8. Level I Program Mode

## Control Operation During A Power Failure



In the event of power failure, the valve will keep track of the time and day for 48 hours. The programmed settings are stored in a non-volatile memory and will not be lost during a power failure.

If power fails while the unit is in regeneration, the valve will return to the service position once power is restored. However, since the unit did not complete its regeneration, it will queue another regeneration at the next scheduled regeneration time.

If the valve misses a scheduled regeneration due to a power failure, it will queue a regeneration at the next regeneration time once power is restored.

## Level II Master Programming



When the Level Two Master Programming Mode is entered, all available option setting displays may be viewed and set as needed. Depending on current option settings, some parameters cannot be viewed or set.

1. If screen is locked, press “ MENU” for 3 seconds to unlock screen.
2. Press and hold “ ” for three seconds to enter Level Two Master Programming.



PARAMETER	OPTIONS	DESCRIPTION	
1	SYSTEM LANGUAGE	This option controls which language should be used in the valve display.	
	ENGLISH		
	FRENCH		
2	VALVE OPERATION	There are three basic operating modes to choose depending on the system application.	
	SOFTENER		
	FILTER		
3	REGEN. MODE	METER DELAYED	This is the most common setting. When the volume remaining reaches zero gallons, the system will initiate a regeneration at the next pre-set regeneration time.
	METER IMMEDIATE	The unit will initiate a regeneration immediately after the volume remaining reaches zero.	
	CALENDAR CLOCK	The unit will initiate a regeneration at the next pre-set regeneration time based on the interval of days between regeneration days.	
	METER OVERRIDE	When the volume remaining reaches zero gallons, the system will initiate a regeneration at the next pre-set regeneration time. If the days between regeneration is reached before the remaining volume reaches zero, the system will override the meter setting and initiate a regeneration.	
4	REGENERATION TIME	This setting controls the time of day when a regeneration cycle will start.	
5	CAPACITY CALC.	AUTOMATIC	This option automatically calculates the capacity (in gallons for meter units), refill time (in minutes), or regeneration day intervals (days for calendar clock mode).
	MANUAL	The user can manually enter values for capacity, refill time, or regeneration day intervals.	
6	RESIN VOLUME	This value should be the amount of resin in cubic feet that is loaded in to the tank. The value is used to calculate the system capacity and refill time.	
7	SALT SETTING	This value is the salt dosage (pounds per cubic foot) to be used when regenerating the system.	
8	REFILL FLOW RATE	This value is the flow rate(gallons per minute) of the brine line flow control (BLFC) button installed in the valve and is used to calculate the refill time to precisely measure the amount of water into the brine tank. (Note: This value is factory preset and should not be changed unless the BLFC button has been changed to a different size.)	
9	UNIT CAPACITY	This value (GRAINS for softeners, PPM for IRON FILTERS) is the total capacity of the system. It is used to calculate the capacity of the system in gallons.	
10	CAPACITY	In MANUAL CAPACITY CALC. mode, the CAPACITY can be adjusted by the user. In AUTOMATIC CAPACITY CALC. mode, the current calculated value is displayed but cannot be adjusted.	
	FORMULA	$CAPACITY = (UNIT\ CAPACITY / WATER\ HARDNESS) - (NUMBER\ PEOPLE * DAILY\ USAGE)$	
11	DAILY USAGE	This value is the average amount of water used per person per day. It is used to calculate the REGEN. DAYS for calendar clocks.	
12	RESERVE CAPACITY	This value is the amount of water per person in gallons to be saved for a reserve capacity. It is used to calculate the CAPACITY of the system.	
13	REGEN. DAYS	This value is the interval (days) between regenerations. It is used to determine how many days between regenerations in the CALENDAR CLOCK mode. It is also used as the value for the METER OVERRIDE mode. It can be set by the user in MANUAL CALC. MODE. In AUTOMATIC CAPACITY CALC. mode, the current calculated value is displayed but cannot be adjusted.	
	FORMULA	$REGEN.\ DAYS = ((UNIT\ CAPACITY / WATER\ HARDNESS) / (NUMBER\ PEOPLE * DAILY\ USAGE)) - 1$	
14	BACKWASH	This option controls the length of time in minutes for the unit to clean the bed by reversing the flow of water upwards through the bed and out to the drain.	
15	BRINE / RINSE	This option controls the length if time in minutes for the unit to draw regenerant (brine for softeners) from the second tank and slowly rinse it from the top to bottom of the tank.	
16	RINSE	This option controls the length of time to give the tank a final rinse from the top to the bottom in order remove any last traces of the regenerant (brine) from the tank.	
17	REFILL	This option controls the length of time the brine valve will open to refill the second tank (brine tank for softeners) with water in order to produce the regenerate solution (brine for softeners) for the next regeneration cycle. The water is accurately measured through the valves brine line flow control to make a precise quantity of regenerant solution. In MANUAL CAPACITY CALC. mode, the REFILL time can be adjusted by the user. In AUTOMATIC CAPACITY CALC. mode, the current calculated value is displayed but cannot be adjusted.	
	FORMULA	$REFILL = 0.45 * SALT\ SETTING * RESIN\ VOLUME / REFILL\ FLOW\ RATE$	
18	RESTORE DEFAULT	YES	This option allows the current settings to be erased and changed back to the default settings.
	NO		

Figure 9. Level II Program Mode

## Diagnostics Mode

1. If screen is locked, press “ MENU” for 3 seconds to unlock.
2. Press and hold the “” DOWN button for three seconds to enter Level Diagnostics Mode.  
In this mode, key diagnostics can be viewed for trouble shooting and problem solving. In addition, the values can be reset to zero individually by pressing “ SET/REGEN” for 3 seconds

## Vacation Settings Mode

1. Press “” for three seconds to unlock screen.
2. Press “” to advance to VACATION MODE.
3. Press and hold the “ UP” for three seconds to enter the Vacation Settings Mode. In this mode the length of time for backwash and rinse along with the frequency are set while the valve is in vacation mode.

PARAMETER	DESCRIPTION
REGEN. DAYS	This value is the frequency of how often the unit should perform a brief backwash and rinse.
BACKWASH	This option controls the length of time in minutes for the unit to briefly clean the bed by reversing the flow of water upwards through the bed and out to the drain.
RINSE	This option controls the length of time to give the tank a brief rinse from the top to the bottom in order to remove any stale or stagnant water from the tank.

Figure 10. Vacation Mode Settings

## System Configuration

Suggested Filter Valve Configuration	
Tank Size (Diameter)	Drain Line Flow Control (DLFC)
8"	#4 (3.5 GPM)
9"	#6 (4.0 GPM)
10"	#7 (5.0 GPM)
12"	none

Figure 11. Valve Configurations

Model	CYCLE TIME (MINUTES)			
	BACKWASH	BRINE (AIR DRAW)	RINSE	REFILL
CAN 565BAF/BIF/BIFMN-100	15.0	45	0.0	0.0
CAN 565BAF/BIF/BIFMN-150	15.0	60	0.0	0.0

Figure 12. Suggested Cycle Time Settings

**\*\* NOTE AIR DRAW WILL DEPENDON RAW WATE PRESSURE \*\***  
**FACTORY SETTINGS SHOULD WORK FOR MOST APPLICATIONS**

## Installation Of Bypass

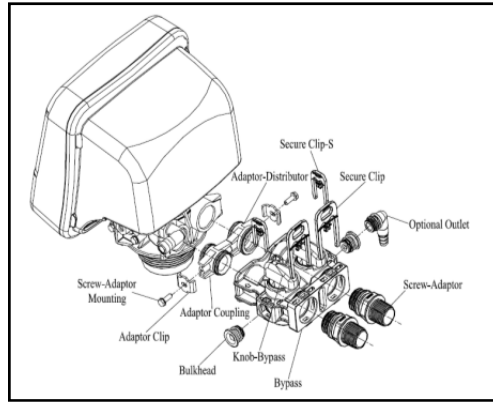

Figure 13. Bypass Assembly View

### Automatic Bypass

Your filter is factory set to backwash at 12:00 a.m. during a period of little or no water use. The backwash and air draw cycle lasts approximately 60 minutes, after which filtered water service is restored. While backwashing is taking place, raw water automatically bypasses the filter if required. If possible, avoid using water during backwashing to prevent iron-laden water from entering your household plumbing system. The filter should not be allowed to regenerate at the same time as any other water treatment units. If adjustment is required, consult programming chart to adjust default regeneration time.)

### New Sounds

You may notice new sounds as your water filter operates. The regeneration cycle lasts approximately 75 minutes. During this time, you may hear water running intermittently to the drain.

### Manual Bypass

In the case of emergency, you can isolate your filter from the water supply using the bypass valve located at the back of the control. In normal operation the bypass is open with the on/off knobs in line with the inlet and outlet pipes. To isolate the filter, simply rotate the knobs clockwise (as indicated by the word BYPASS and arrow) until they lock. You can use your water related fixtures and appliances as the water supply is bypassing the filter. However, the water you use will be untreated. To resume treated water service, open bypass valve by rotating the knobs counterclockwise.

## Maintenance

---

Maintenance of your new water filter requires very little time or effort but it is essential. Regular maintenance will ensure many years of efficient and trouble-free operation.

1. Periodically make sure your pump is performing satisfactorily to ensure sufficient water is available for backwashing the filter.
2. Periodically test your raw and filtered water to ensure conditions are still the same for your original settings and that the unit is working the way it is intended to.

***\*\*Periodic water testing is the best way to determine when the filter media will require replacement.***

3. Periodically check that the drain line is free from any obstructions.

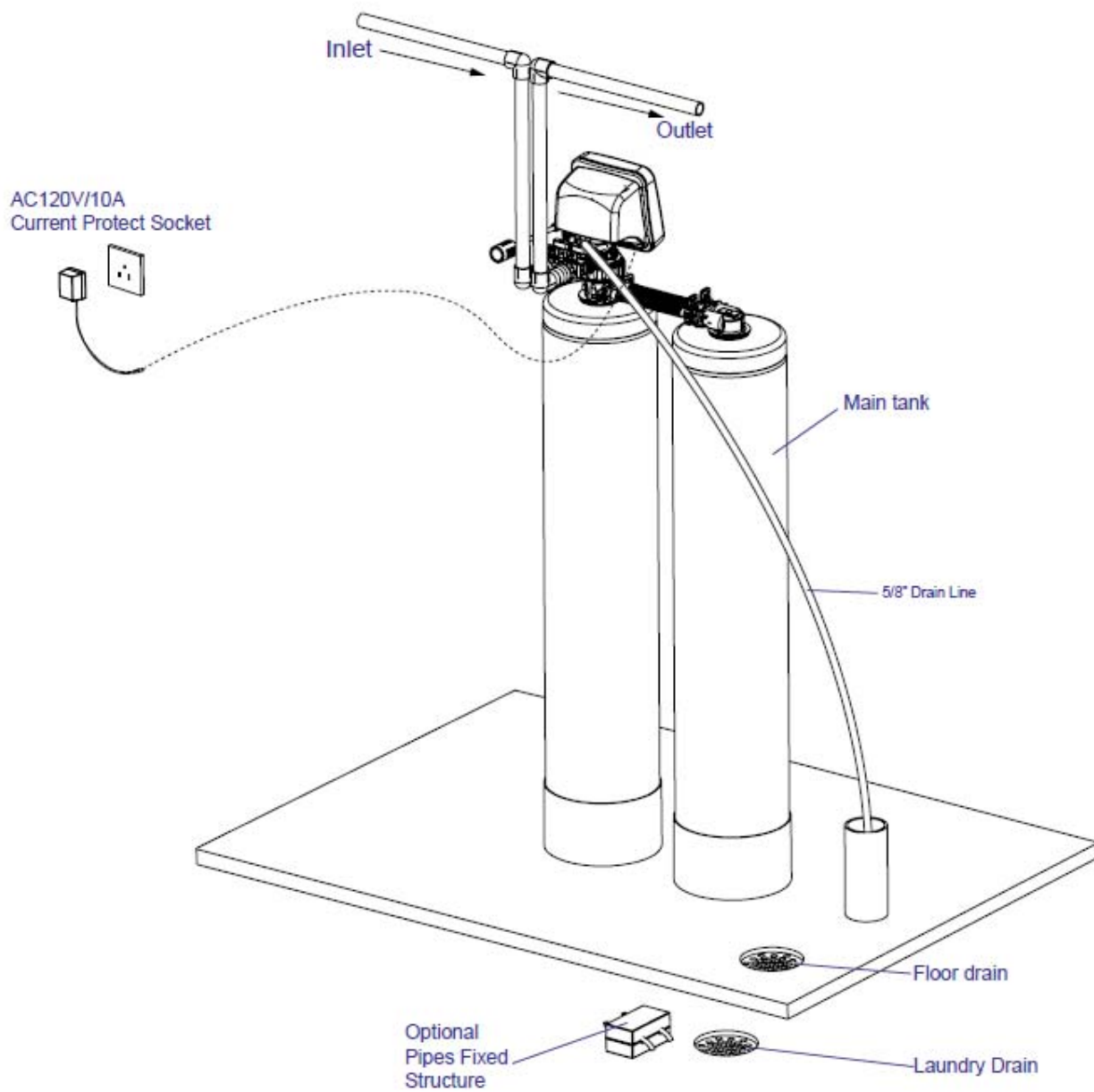

## Valve Drive Assembly Exploded View

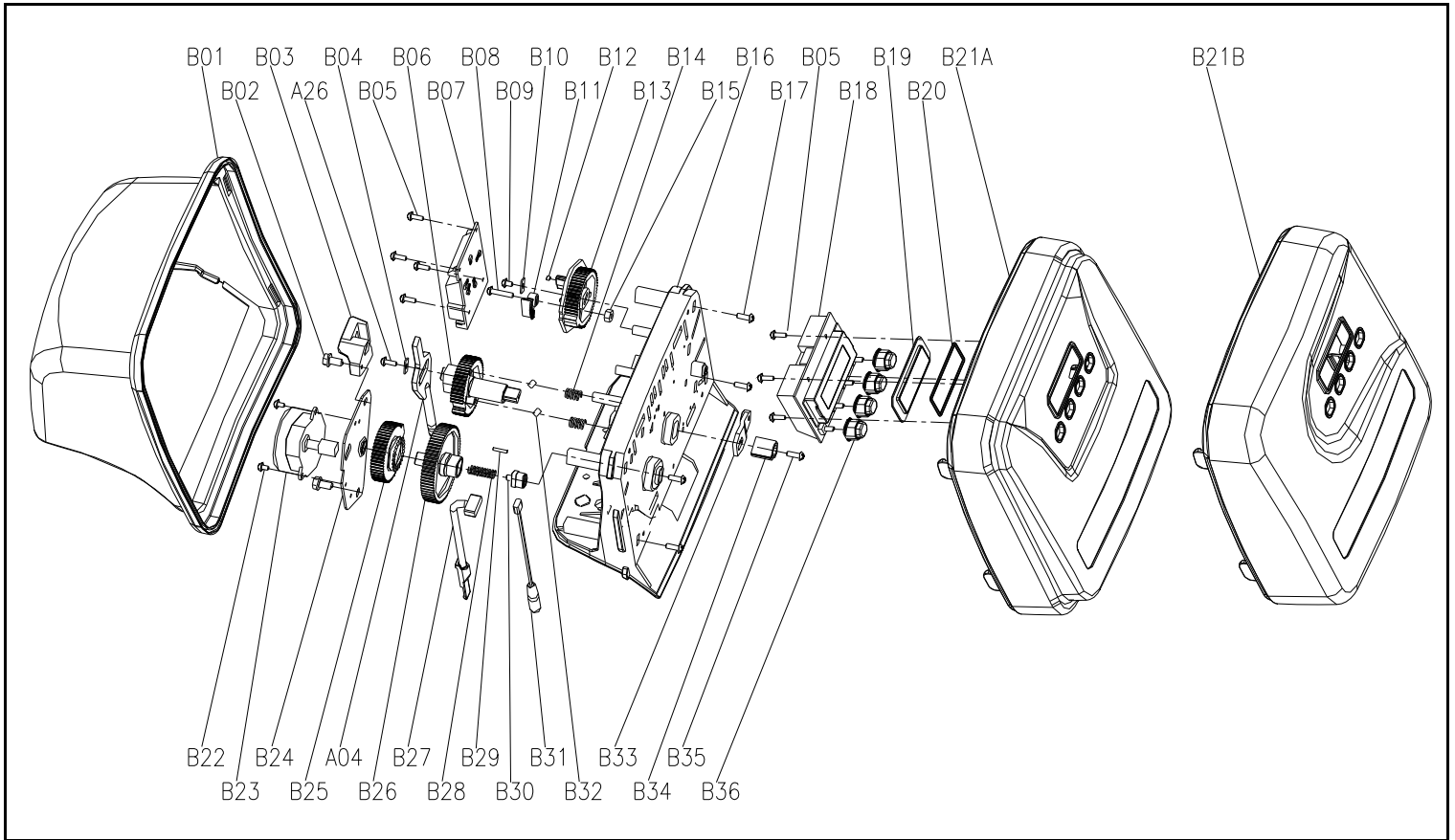

Item No.	PartNo.	Part Description	Quantity
B01	05056523	Bnt365 Cover	1
B02	05056136	Screw-ST3.5×13(Hexagon with Washer)	2
B03	05010045	Piston Stem Holder	1
A26	13000426	Screw-ST2.9×13(Large Washer)	1
B04	05056139	Washer-3x13	1
B05	05010037	Screw-ST2.9×10	8
B06	05056005	Main Gear	1
B07	05030010	Bnt85 Main Pcb	1
B08	05056083	Screw-M4x14	1
B09	05056166	Screw-ST4.2×12(Large Washer)	1
B10	05056141	Washer-4x12	1
B11	05056016	Brine Regulator	1
B12	05010023	Magnet-48×2.7	1
B13	05056015	Brine Gear	1
B14	05056095	Spring Detent	2
B15	05056089	Nut-M4	1
B16	05056522	Bnt365 Housing	1
B17	05056084	Screw-ST3.5x13	4
B18	05030020	Bnt85 Display(NOV0)	1
	05056536	Bnt465 Wiring Harness	1
B19	05056528	Pcb Cover	1
B20	26010047	O-Ring-40×1.8	1

Item No.	PartNo.	Part Description	Quantity
B21A	05056527	Bnt465 Front Cover	1
B21B	05056531	Bnt565 Front Cover	1
B22	05056082	Screw-M3×5	2
B23	05056510	Motor-12v/2rpm	1
	05030014	Motor Power Cable	1
	11700005	Wire Connector	2
B24	05056045	Motor Mounting Plate	1
B25	05056501	Drive Gear	1
A04	05010081	Bnt65 Piston Rod	1
B26	05056002	Helix Gear	1
B27	05010031	Meter Assembly	1
	05010046	Meter Stand Relief	1
B28	05056094	Spring Helix	1
B29	05056098	Motor Pin	1
B30	05056502	Spring Retainer	1
B31	05010029	Power Cable	1
	05056013	Power Stand Relief	1
B32	05056092	Ball-1/4 inch	2
B33	05056503	Magnet Holder	1
B34	05056554	Locking Knob	1
B35	05056561	Screw-ST3.5×15(CSK)	1
B36	05056529	Bnt465 Button	4

# Control Valve Assembly Exploded View

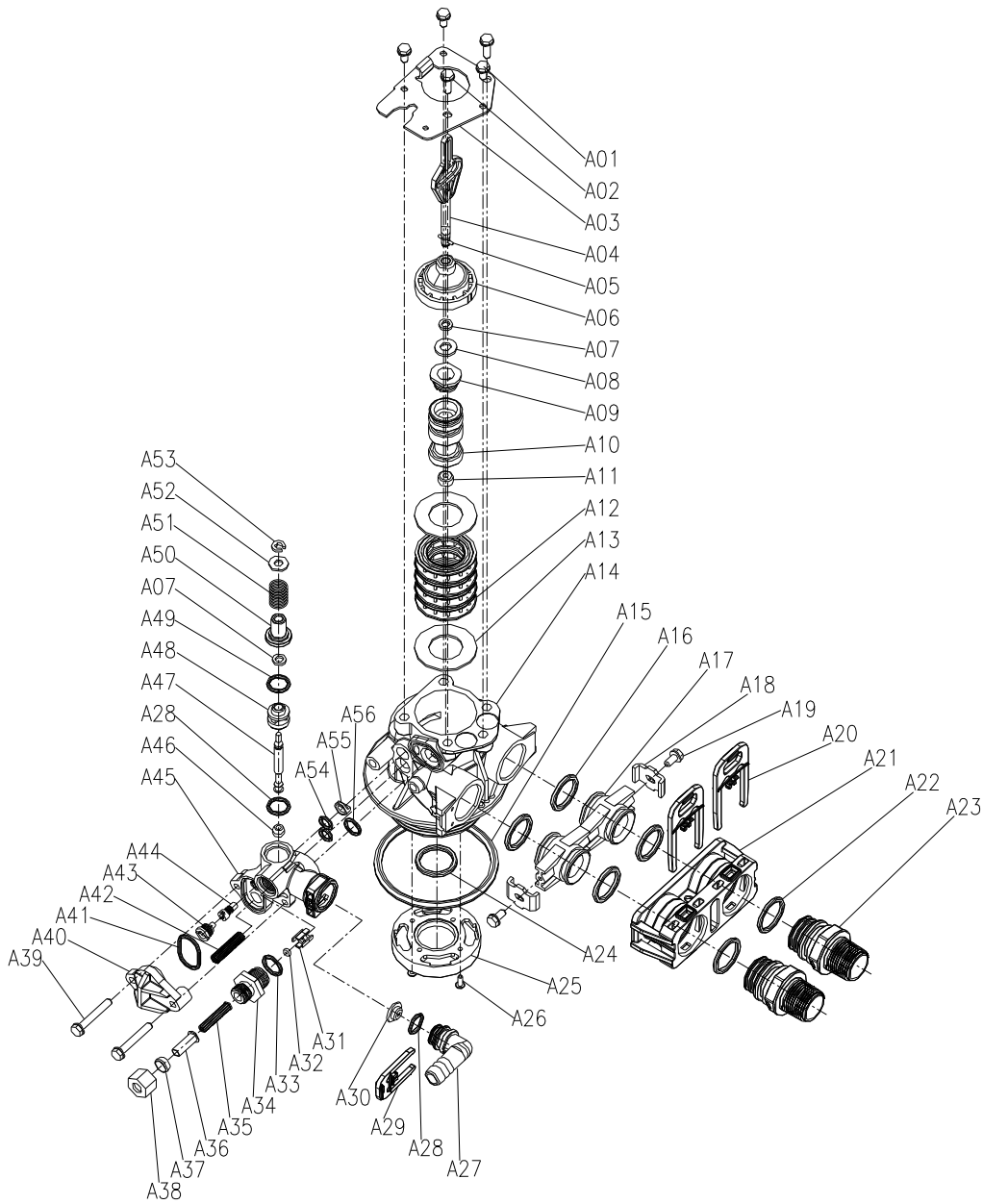

See parts listing on next page (17)

## Control Valve Parts List

Item No.	Part No.	Part Description	Quantity
A01	05056087	Screw-M5×12(Hexagon)	3
A02	05056088	Screw-M5×16(Hexagon with Washer)	2
A03	05056047	End Plug Retainer	1
A04	05010081	Bnt65 Piston Rod	1
A05	05056097	Piston Pin	1
A06	05056023	End Plug	1
A07	05056070	Quad Ring	2
A08	05056024	End Plug Washer	1
A09	05056022	Piston Retainer	1
A10	05056181	Piston (Electrical)	1
A11	05056104	Muffler	1
A12	05056021	Spacer	4
A13	05056073	Seal	5
A14	05056019	Bnt65 Valve Body	1
A15	05056063	O-ring-φ78.74×5.33	1
A16	05056129	O-ring-φ23×3	4
A17	05056025	Adaptor Coupling	2
A18	05056044	Adaptor Clip	2
A19	05056090	Screw-ST4.2×13(Hexagon with Washer)	2
A20	21709003	Secure Clip	2
A21	05056140	Valve Connector	1
A22	05056065	O-ring-φ23.6×2.65	2
A23	21319006	Screw Adaptor	2
A24	26010103	O-ring-φ25×3.55	1
A25	07060007	Valve Bottom Connector	1
A26	13000426	Screw-ST2.9×13(Large Wafer)	2
A27	05010082	Drain Fitting	1
A28	05056134	O-Ring-φ12×2	1
A29	05056172	Secure Clip-S	1
A30	05056186	DLFC-2#	1
A32	05056035	BLFC Button Retainer	1
A33	05056191	BLFC-2#	1
A34	05056138	O-Ring-φ14×1.8	1
A35	05056100B	BLFC Fitting	1
A36	05056106	Brine Line Screen	1
A37	05056107	BLFC Tube Insert	1
A38	05056033	BLFC Ferrule	1
A39	05056108	BLFC Fitting Nut	1
A40	05056086	Screw-M5×30(Hexagon with Washer)	2
A41	05056029	Injector Cover	1
A42	05056072	O-Ring-φ24×2	1
A43	05056103	Injector Screen	1
A44	05056027	Injector Nozzle	1
A45	05056028	Injctor Throat	1
A46	05056177	Injector Body	1
A47	05056075	Injector Seat	1
A48	05056134	O-Ring-φ12×2	1
A49	05056054	Injector Stem	1
A50	05056031	Injector Spacer	1
A51	05056081	O-Ring-φ12.5×1.8	1
A52	05056030	Injector Cap	1
A53	05056093	Injector Screen	1
A54	05010049	Special Washer	1
A55	05056105	Retaining Ring	1
A56	05056067	O-Ring-φ7.8×1.9)	2
A57	05056037	Air Disperser	1
A58	05056066	O-Ring-φ11×2	1

## Trouble Shooting

Issue	Possible Cause	Possible Solution
A. Water clear when drawn; turns red upon standing (stain producing)	1. Insufficient air in air tank.	a) Increase Brine Time (air draw) <span style="float: right;">b) Check valve not working.</span>
	2. Bypass open or leaking	Close bypass and/or repair as necessary.
	3. Filter bed overloaded with precipitated iron due to insufficient backwash	Increase backwash frequency. Upon correction of problem, manually backwash until backwash water starts to clear. In more severe iron-fouling cases, bed may need chemical cleaning - contact dealer.
	4. Presence of manganese or tannins	Recheck water analysis
	5. Flow rate excessive for model	Reread "Sizing Requirements" Page 5-6.
B. Water red when drawn from tap	1. Filter bed overloaded with precipitated iron due to insufficient backwash flow rate	a. Recheck well pumping rate for backwash and repair or replace as required. b. Check for obstructions or kink in drain line c. For improper drain line flow controller, see specs. Upon correction of this problem, if manually backwashing does not clear bed of iron, filter bed may need chemical cleaning - contact dealer.
	2. Filter bed overloaded with precipitated iron due to insufficient backwash	Increase backwash frequency. Upon correction of problem, manually backwash until backwash water starts to clear. In more severe iron-fouling cases, bed may need chemical cleaning - contact dealer.
	3. Insufficient air in air tank.	a) Increase Brine Time (air draw) <span style="float: right;">b) Check valve not working.</span>
C. Excessive pressure loss through filter	1. Filter bed overloaded with precipitated iron.	See problem above
	2. Control inlet/outlet valve(s) not fully open	Open valves
	3. Sand, silt or mud collecting in filter bed	Check well for these conditions
	4. Filter bed not properly classified	Manually backwash to reclassify
D. Milky or bubbly water (appears to contain small bubbles)	1. Common with this type of filter.	None.
	2. Excess gases in water (carbon dioxide, hydrogen sulphide, methane)	May require draining of water system or installation of air relief control - contact dealer.
E. Unit fails to initiate a regeneration cycle.	1. No power supply.	Check electrical service, fuse, etc.
	2. Defective circuit board.	Replace faulty parts.
	3. Power failure.	Reset time of day.
F. Low water pressure.	1. Iron or scale build up in line feeding unit.	Clean pipes.
	2. Iron build up inside valve or tank.	Clean control and add resin cleaner to clean bed. Increase regeneration frequency.
	3. Inlet of control plugged due to foreign material.	Remove piston and clean control valve.
G. Filter media in drain line.	1. Air in water system.	Check well system for proper air eliminator control.
	2. Incorrect drain line flow control (DLFC) button.	Check for proper flow rate.
H. Valve continuously cycles.	1. Defective position sensor PCB.	Replace faulty parts.
I. Flow to drain continuously.	1. Valve settings incorrect.	Check valve settings.
	2. Foreign material in control valve.	Clean control.
	3. Internal leak.	Replace seals, spacers, and piston assembly.

# Manufacturers Warranty

**Canature Watergroup** warrants that your new water conditioner is built of quality material and workmanship. When properly installed and maintained, it will give years of trouble free service.

## **Five Year Complete Parts Warranty:**

**Canature WaterGroup** will replace any part which fails within 60 months from date of manufacture, as indicated by the serial number, provided the failure is due to a defect in material or workmanship. The only exception shall be when proof of purchase or installation is provided and then the warranty period shall be from the date thereof.

## **Ten Year Warranty on Mineral Tanks and Brine Tanks:**

**Canature WaterGroup** will provide a replacement mineral tank or brine tank to any original equipment purchaser in possession of a tank that fails within 120 months, provided that the water conditioner is at all times operated in accordance with specifications and not subject to freezing.

## **General Provisions:**

Damage to any part of this water conditioner or filter as a result of misuse, misapplication, neglect, alteration, accident, installation or operation contrary to our printed instructions, damage to ion exchange resin and seals caused by chlorine / chloramines in the water supply, or damage caused by any force of nature is not covered in this warranty. We will repair or replace defective parts if our warranty department determines it to be defective under the terms of this warranty. Canature assumes no responsibility for consequential damage, labour or expense incurred as a result of a defect or failure.